

**Schutz-Temperatur-Begrenzer fest eingestellt bei/
Thermal cut-out fixed set at/
Termostato elettrico a ripristino temperatura fissa:
235°C ±9K "AUS/OFF/SPENTO"**

Begrenzerkontakt schaltet nach Erreichen der eingestellten Temperatur aus und wird gesperrt. Nach genügender Abkühlung des Temperaturfühlers kann durch Drücken des Rückstellknopfes wieder eingeschaltet werden./
Limiter contact switches off after achieving the adjusted temperature and will be blocked. After sufficient cooling of the sensor thermal cut-out can be reset by pressing the reset button./
L'aumento della temperatura provoca l'apertura del contatto. Dopo un adeguato raffreddamento del bulbo mediante pressione sul pulsante il contatto si richiude.

Schalt-schema/
Wiring diagram/
Schema elettrico

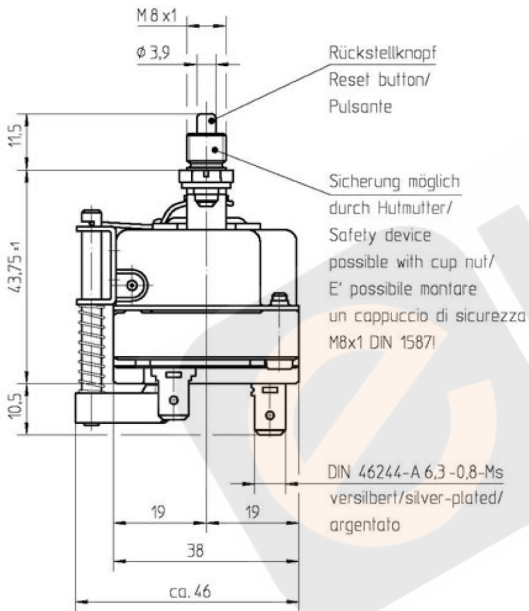
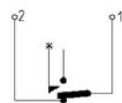

Lose mitgeliefert/Loosly supplied/
Forniture separate:/
1x Sechskantmutter/Hex nut/
Dado M8x1 SW12 0000 600.065

Übergangswiderstand max./Contact resistance max./
Resistenza di passaggio massima 15 mΩ
Kontakte hart vergoldet/Contacts hard-gold plating/
Contatto dorato min. 3 my
Max. Schaltleistung von/Max. switching capacity of/
Capacità massima di commutazione 0,5A 12V-
nicht überschreiten./not to cross/non superare.

Genehmigte technische Daten/Approved technical data/
Dati tecnici di omologazione 55.19500.000, Bl. 901

Bemerkungen/Notes/Note:

Normalklima/Standard atmosphere/
Condizioni ambiente DIN EN 60068-1 (23±2)°C
Temperaturen sind AUS-Werte/Temperatures are OFF values/
Temperature riferite all'apertura contatto
Min. Fühlertemperatur/Min. sensor temperature/
Minima temperatura bulbo: -10°C (DC)
Max. Fühlertemperatur/Max. sensor temperature/
Max. temperatura bulbo: 370°C
(aus Sicherheitsgründen/for security reasons/per motivi di sicurezza)
Schnappfeder/Snap action spring/Molla: NiBe
Max. Gehäusetemperatur/Max. housing temperature/
Max. temp. circonferenz (VDE): 150°C
Max. Gehäusetemperatur/Max. housing temperature/
Max. temp. circonferenz (UL): 120°C
Min. Biegeradius Kapillarrohr/Min. bending radius of capillary tube/
Minimo raggio capillare: 5 mm
Für Einsatz in Umgebungsbedingungen mit normaler Verunreinigung/
Far application with normal pollution level/
Per utilizzo in normali condizioni ambientali (Typ 2 B D)
Kunden-Zeichnungs-Nr./Customer drawing-Na./Codice Cliente:

Korrekturfaktor/Correction factor/
Fattore di correzione: c = 0,34 (K/K)
(bez. auf Umgebungtemp./based on ambient temperature/
riferito alla normale temperatura ambiente)

This document is exclusively committed to you for the agreed purpose. Any kind of duplication, utilization or communication of its content is prohibited, if not expressly conceded otherwise. Violators are committed to pay compensations. Any claims of existing or future property rights remain unaffected.				Blank No. EN Mat.No.	Scale Unit mm	
				Material	Scale 1:1	
				Surface Texture ISO 1302 General Tolerances ISO 2768-v		
2	CD0001	2010-12-15	CAD	Date	Name	Designation
1	E14917	2010-12-16	Create	2004-12-15	KESSELBG	EGO Schutz-Temperatur-Begrenzer
Cha.	Information No.	Date	Proc.	2010-12-16	POSOVSKY	EGO Thermal cut out
F.Rel.	E04172	2004-12-15	Ret.	2010-12-16	KESSELBG	EGO Termostato elettrico a ripristino
				Drawing No.	Sh.No.	Ver.
				55.19542.130	901	1 F 1
Origin 55.10542.805				Repl.for	Repl.by	Reference