

Technical Data Sheet

Compressor model **HPY12AAa**
 Voltage **220-240V 50Hz ~1**
 Refrigerant **R600a**

APPLICATION

Application Low Back Pressure
 Refrigerant R600a
 Evaporating Temp. -35,0 °C to -10,0 °C
 Expansion Capillar
 Comp. Cooling Static
 Max. ambient temp. 43,0 °C

COMPRESSOR

Displacement 12,10 cm³
 Diameter 27,00 mm
 Stroke 21,13 mm
 Net Weight 11,13 Kg
 Oil type ISO VG 10 MINER
 Oil charge 300 cm³

MOTOR

Nominal Power 1/5 hp
 Voltage/Frequency 220-240V 50Hz
 Voltage range 187-264 V
 Type RSIR
 Phase number 1 PH
 Locked Rotor Amps (LRA) 10,90 A
 Max. Cont. Current (MCC) 1,20 A
 Main W. resist. at 25°C 14,17 Ω
 Start W. resist. at 25°C 18,25 Ω

NOMINAL PERFORMANCE

	ASHRAE	CECOMAF
Cooling Capacity	165 kCal/h	144 W
COP	1,43 W/W	1,13 W/W
EER	1,23 kCal/Wh	0,97 kCal/Wh
Input Power	134 W	128 W
Current	0,86 A	0,84 A

APPROVALS



TEST CYCLE CONDITIONS

	ASHRAE LBP (B)	CECOMAF LBP (A)
Evaporating temp. (T _e)	-23,3 °C	-25,0 °C
Condensing temp. (T _c)	55,0 °C	55,0 °C
Liquid temp. (T _{liq.})	32,0 °C	55,0 °C
Ambient temp. (T _{amb.})	32,0 °C	32,0 °C
Suction temp. (T _{suction})	32,0 °C	32,0 °C
Voltage/Frequency	220 V 50 Hz	220 V 50 Hz

ELECTRICAL COMPONENTS

Relay	Option 1			
Reference	PTC K100			
Voltage	200-240 V			
Resistance	14.00 Ω			
Protector	Option 1	Option 2	Option 3	Option 4
Reference	MSP327LZ	4TM265NFBYY	T0500	AE18FU
Current	6,30 A	9,20 A	5,70 A	6,30 A
Time check	7,5-14 seg	5-15 seg	7,5-14 seg	7,5-14 seg
Disc temp. (Open/Close)	120,00 / 61,00 °C	120,00 / 61,00 °C	135,00 / 62,00 °C	120,00 / 62,00 °C

This product is approved for R290 and R600a regarding explosion safety according to standard EN 60335-1 and EN 60335-2-34

ASHRAE

Tc °C	Te °C	Cooling Capacity kCal/h	Consumption W	Current A	COP W/W	EER kCal/Wh
40	-35	100	95	0,74	1,22	1,05
40	-30	134	109	0,78	1,43	1,23
40	-25	175	124	0,83	1,65	1,42
40	-23,3	191	129	0,84	1,73	1,48
40	-20	225	140	0,88	1,88	1,62
40	-15	284	156	0,94	2,11	1,81
40	-10	350	174	1,01	2,34	2,01

45	-35	94	94	0,74	1,16	1,00
45	-30	126	109	0,78	1,35	1,16
45	-25	167	125	0,83	1,55	1,34
45	-23,3	183	131	0,85	1,63	1,40
45	-20	216	142	0,89	1,77	1,52
45	-15	273	160	0,95	1,99	1,71
45	-10	338	178	1,03	2,20	1,90

50	-35	88	94	0,74	1,09	0,94
50	-30	119	110	0,78	1,27	1,09
50	-25	159	126	0,83	1,46	1,25
50	-23,3	174	132	0,85	1,53	1,31
50	-20	206	144	0,90	1,66	1,43
50	-15	262	163	0,97	1,87	1,61
50	-10	326	183	1,05	2,08	1,78

55	-35	82	93	0,74	1,03	0,88
55	-30	112	110	0,78	1,19	1,02
55	-25	150	128	0,84	1,37	1,18
55	-23,3	165	134	0,86	1,43	1,23
55	-20	197	147	0,90	1,56	1,34
55	-15	251	166	0,98	1,76	1,51
55	-10	314	187	1,07	1,95	1,68

60	-35	76	92	0,74	0,96	0,82
60	-30	105	110	0,79	1,11	0,95
60	-25	142	129	0,84	1,28	1,10
60	-23,3	156	136	0,87	1,34	1,15
60	-20	187	149	0,91	1,46	1,26
60	-15	240	170	0,99	1,65	1,42
60	-10	302	191	1,09	1,84	1,58

CECOMAF

Tc °C	Te °C	Cooling Capacity W	Consumption W	Current A	COP W/W	EER kCal/Wh
40	-35	109	95	0,74	1,15	0,99
40	-30	148	109	0,78	1,36	1,18
40	-25	195	124	0,83	1,58	1,36
40	-23,3	213	129	0,84	1,65	1,43
40	-20	250	140	0,88	1,79	1,55
40	-15	312	156	0,94	2,00	1,73
40	-10	383	174	1,01	2,20	1,90

45	-35	99	94	0,74	1,05	0,91
45	-30	135	109	0,78	1,23	1,07
45	-25	178	125	0,83	1,42	1,23
45	-23,3	195	131	0,85	1,49	1,29
45	-20	229	142	0,89	1,62	1,40
45	-15	288	160	0,95	1,81	1,56
45	-10	355	178	1,03	1,99	1,72

50	-35	89	94	0,74	0,95	0,82
50	-30	121	110	0,78	1,10	0,95
50	-25	161	126	0,83	1,27	1,10
50	-23,3	176	132	0,85	1,33	1,15
50	-20	209	144	0,90	1,45	1,25
50	-15	264	163	0,97	1,62	1,40
50	-10	328	183	1,05	1,79	1,55

55	-35	79	93	0,74	0,85	0,73
55	-30	107	110	0,78	0,98	0,84
55	-25	144	128	0,84	1,13	0,97
55	-23,3	158	134	0,86	1,18	1,02
55	-20	188	147	0,90	1,28	1,11
55	-15	240	166	0,98	1,45	1,25
55	-10	301	187	1,07	1,61	1,39

60	-35	68	92	0,74	0,74	0,64
60	-30	94	110	0,79	0,85	0,73
60	-25	127	129	0,84	0,98	0,85
60	-23,3	140	136	0,87	1,03	0,89
60	-20	168	149	0,91	1,13	0,97
60	-15	217	170	0,99	1,28	1,10
60	-10	273	191	1,09	1,43	1,23

EN12900

X	Cooling Capacity (W)	Consumption (W)	Current (A)	Mass Flow (kg/h)
1	810,9189674710	165,4696786939	0,9943981324	8,1944880536462
2	23,0966246402	2,5002843797	0,0147310966	0,25650888571689
3	-6,9297102303	1,2950732931	0,0057115683	-0,037839949912592
4	0,1519368674	0,0199930136	0,0002327498	0,0022084603565255
5	-0,1394503777	0,0408920292	0,0001730718	-0,00063588096500096

Equation	$x_1 + x_2Te + x_3Tc + x_4Te^2 + x_5TeTc$
----------	---

Technical Data Sheet

COMPRESSOR DIMENSIONS

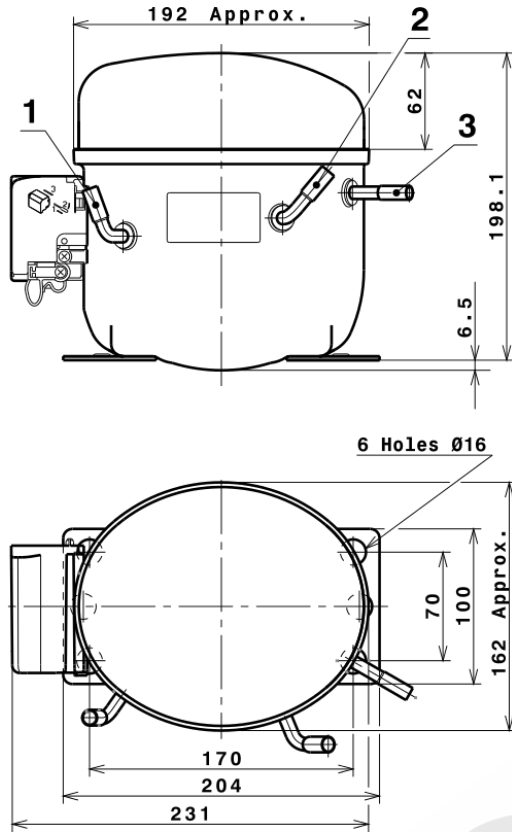

DESIGNATION

INTERNAL DIAM.

1	Suction	8,1 mm
2	Service	8,1 mm
3	Discharge	6,5 mm

WIRING DIAGRAMS AND ELECTRICAL ASSEMBLY

RSIR CONNECTION (PTC) (L, P ranges)

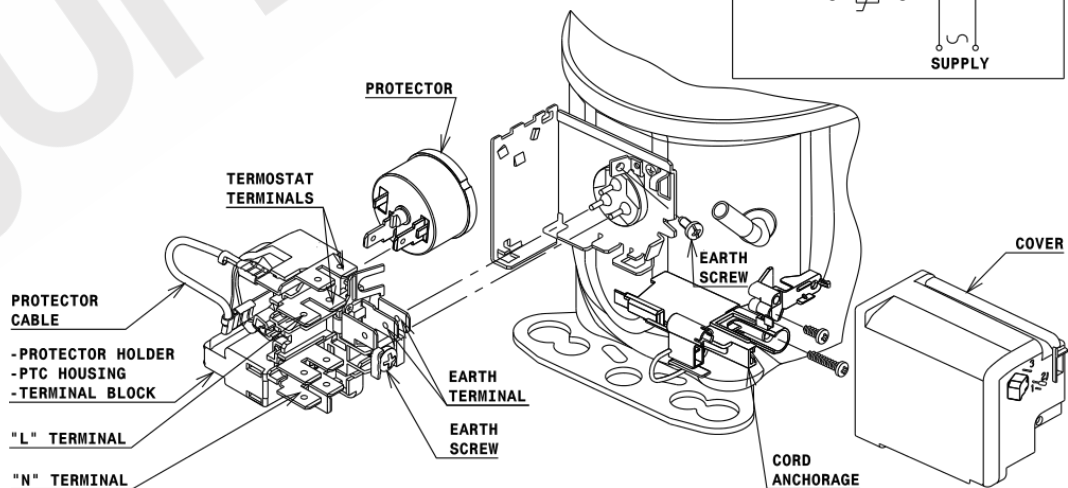
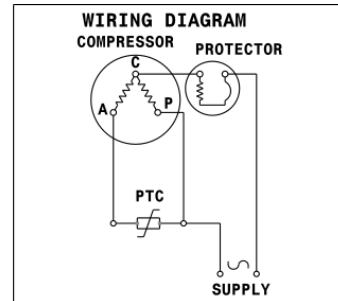

Technical Data Sheet

FIXINGS

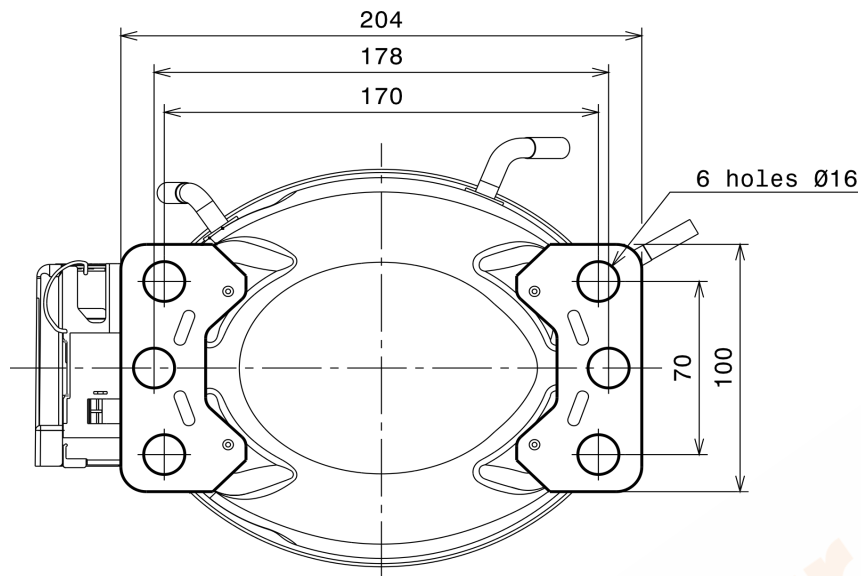

SILENT BLOCKS (MOUNTING ACCESSORIES)

STANDARD

Ø16 holes (170x70 net)

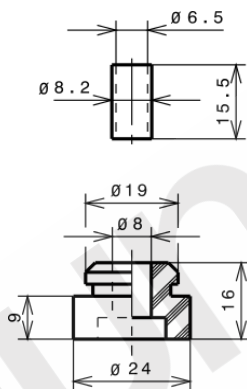

SNAP-ON

Ø16 holes (170x70 net)

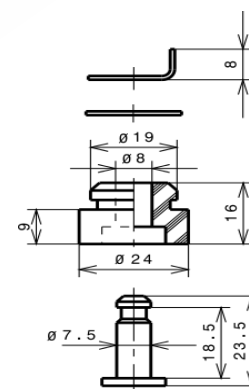

SOA

SOA R600a LBP

