

## SC15G Universal Compressor R134a 220-240V 50/60Hz

### General

Code number	104G8525
Approvals	EN 60335-2-34
Compressors on pallet	80

### Application

Application	LBP/HBP		
Frequency	Hz	50	60
Evaporating temperature	°C	-25 to 15	-25 to 15
Voltage range	V	187 - 254	198 - 254
Max. condensing temperature continuous (short)	°C	60 (70)	60 (70)
Max. winding temperature continuous (short)	°C	125 (135)	125 (135)

### Cooling requirements

Frequency	Hz	50			60		
Application		LBP	MBP	HBP	LBP	MBP	HBP
32°C		F <sub>1</sub>	F <sub>2</sub>	F <sub>2</sub>	F <sub>1</sub>	-	-
38°C		F <sub>1</sub>	F <sub>2</sub>	F <sub>2</sub>	F <sub>1</sub>	-	-
43°C		F <sub>1</sub>	F <sub>2</sub>	F <sub>2</sub>	F <sub>1</sub>	-	-

Remarks on application: HBP at 198 - 254V 50Hz only.

### Motor

Motor type	CSIR		
LRA (rated after 4 sec. UL984), HST   LST	A	14.8	-
Cut in Current, HST   LST	A	14.8	-
Resistance, main   start winding (25°C)	Ω	5.0	13.7

### Design

Displacement	cm <sup>3</sup>	15.28
Oil quantity (type)	cm <sup>3</sup>	600 (polyolester)
Maximum refrigerant charge	g	1300
Free gas volume in compressor	cm <sup>3</sup>	1410
Weight without electrical equipment	kg	13.1

### Dimensions

Height	mm	A	209
		B	203
		B1	183
		B2	100
Suction connector	location/I.D. mm   angle	C	10.2   37°
	material   comment		Copper   Rubber plug
Process connector	location/I.D. mm   angle	D	6.5   37°
	material   comment		Copper   Rubber plug
Discharge connector	location/I.D. mm   angle	E	6.5   37°
	material   comment		Copper   Rubber plug
Oil cooler connector	location/I.D. mm   angle	F	-
	material   comment		-
Connector tolerance	I.D. mm		±0.09
Remarks:			

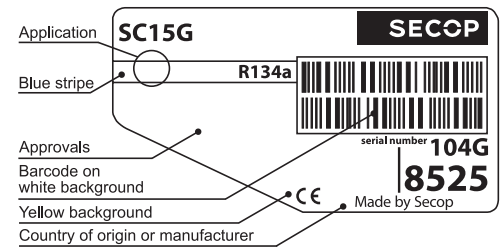

- S = Static cooling normally sufficient
- O = Oil cooling
- F<sub>1</sub> = Fan cooling 1.5 m/s  
(compressor compartment temperature equal to ambient temperature)
- F<sub>2</sub> = Fan cooling 3.0 m/s necessary
- SG = Suction gas cooling normally sufficient
- = not applicable in this area

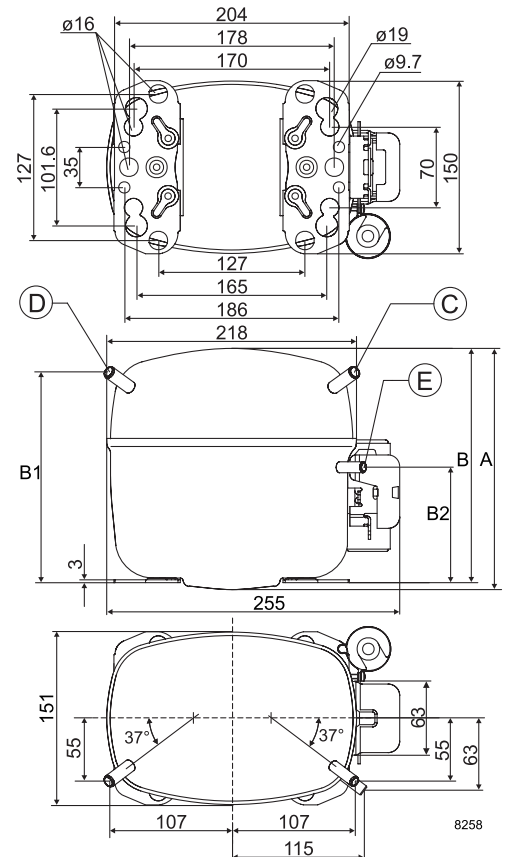

**EN 12900 Household (CECOMAF)** 220V, 50Hz, fan cooling F<sub>2</sub>

Evap. temp. in °C	-45	-40	-35	-30	-25	-23.3	-20	-15	-10	-6.7	-5	0	5	7.2	10	15	20
Capacity in W					164	206	290	424	568	672	728	908	1110	1207	1340	1600	
Power cons. in W					233	259	307	376	440	478	497	549	595	613	634	667	
Current cons. in A					2.21	2.28	2.40	2.59	2.78	2.92	2.99	3.20	3.42	3.52	3.64	3.88	
COP in W/W					0.71	0.80	0.95	1.13	1.29	1.40	1.46	1.65	1.87	1.97	2.11	2.40	

**ASHRAE LBP** 220V, 50Hz, fan cooling F<sub>2</sub>

Evap. temp. in °C	-45	-40	-35	-30	-25	-23.3	-20	-15	-10	-6.7	-5	0	5	7.2	10	15	20
Capacity in W					203	255	358	523	703	831	901	1124	1377	1499	1665	1993	
Power cons. in W					233	259	307	376	440	478	497	549	595	613	634	667	
Current cons. in A					2.21	2.28	2.40	2.59	2.78	2.92	2.99	3.20	3.42	3.52	3.64	3.88	
COP in W/W					0.87	0.99	1.17	1.39	1.60	1.74	1.81	2.05	2.31	2.44	2.62	2.99	

**EN 12900 Household (CECOMAF)** 220V, 60Hz, fan cooling F<sub>2</sub>

Evap. temp. in °C	-45	-40	-35	-30	-25	-23.3	-20	-15	-10	-6.7	-5	0	5	7.2	10	15	20
Capacity in W					262	298	376	515	677	797	863						
Power cons. in W					330	350	388	447	506	544	563						
Current cons. in A					1.99	2.05	2.17	2.37	2.59	2.74	2.82						
COP in W/W					0.79	0.85	0.97	1.15	1.34	1.47	1.53						

**ASHRAE LBP** 220V, 60Hz, fan cooling F<sub>2</sub>

Evap. temp. in °C	-45	-40	-35	-30	-25	-23.3	-20	-15	-10	-6.7	-5	0	5	7.2	10	15	20
Capacity in W					326	371	468	639	840	988	1070						
Power cons. in W					328	347	386	444	502	540	560						
Current cons. in A					1.97	2.03	2.16	2.36	2.57	2.73	2.81						
COP in W/W					0.99	1.07	1.21	1.44	1.67	1.83	1.91						

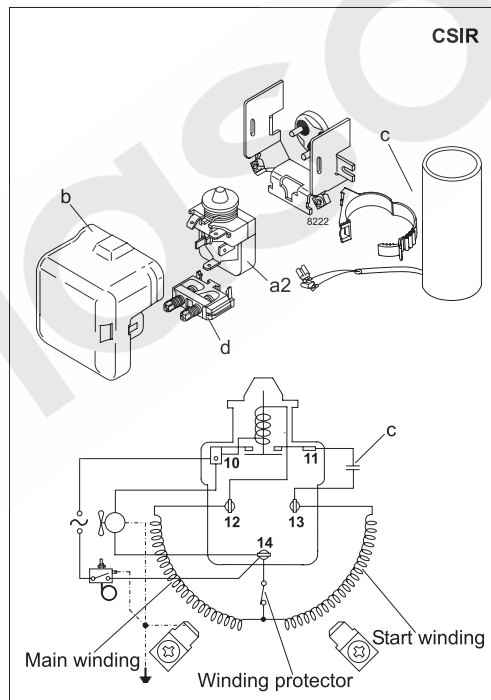

Accessories for	SC15G	Figure	Code number	Test conditions	EN 12900/CECOMAF	ASHRAE LBP
PTC starting device	6.3 mm spade connectors	a1	-	Condensing temperature	55°C	55°C
	4.8 mm spade connectors		-	Ambient temperature	32°C	32°C
Starting relay	6.3 mm spade connectors	a2	117U6005	Suction gas temperature	32°C	32°C
Cover		b	103N2009	Liquid temperature	55°C	32°C
Start. capacitor 80 µF	6.3 mm spade connectors	c	117U5017			
Cord relief		d	103N1004			
Protection screen for PTC		g	-			

Mounting accessories		Code number
Bolt joint for one comp.	Ø: 16 mm	118-1917
Bolt joint in quantities	Ø: 16 mm	118-1918
Snap-on in quantities	Ø: 16 mm	118-1919

Secop can accept no responsibility for possible errors in catalogues, brochures and other printed material. Secop reserves the right to alter its products without notice. This also applies to products already on order provided that such alterations can be made without consequential changes being necessary in specifications already agreed. All trademarks in this material are property of the respective companies. Secop and the Secop logotype are trademarks of Secop GmbH. All rights reserved. [www.secop.com](http://www.secop.com)