



SITGroup

630 EUROSIT



**MULTIFUNCTIONAL GAS CONTROL WITH
THERMOELECTRIC FLAME SUPERVISION
DEVICE**



Multifunctional control with modulating thermostat and additional on-off function. 630 EUROSIT does not require electrical supply and is available in a vast range of models. It is particularly suitable for use in space heaters, convector heaters, storage water heaters, boilers, catering appliances and all those appliances that require accurate temperature control.

MAIN CHARACTERISTICS

- Control knob with positions for off, pilot and temperature selection (MS)
- Thermoelectric flame supervision device with re-start interlock (GM)
- Maximum gas flow adjustment (RQ) or, alternatively, Pressure regulator (PR)
- Minimum (by pass) flow adjustment
- Modulating thermostat with additional on-off function (TH)
- Pilot outlet with pre-setting device of the gas flow (RQ)
- Inlet and pilot filter (FL)
- Inlet and Outlet pressure test points
- Lateral or bottom main gas inlet and outlet
- Main gas connections with threaded pipe or nut and olive

WORKING DIAGRAM

Versions without pressure regulator

Versions with pressure regulator

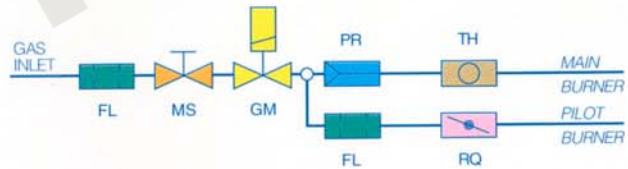
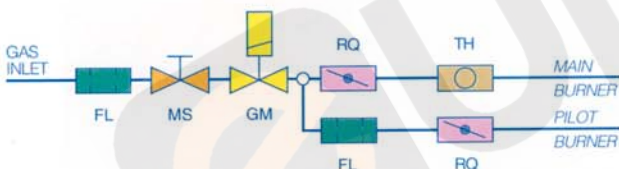

TECHNICAL DATA

The technical data specified below refer to the European standard, EN 126 "Multi-functional controls for gas-burning appliances".

Main gas connections	Rp 1/2 ISO 7
Assembly position	any position
Gas families	I, II and III
Max. gas inlet pressure	50 mbar
Outlet pressure setting range	3-18 mbar
Working temperature range	0-80 °C
Pressure regulator (optional)	Class C
Torsion and bending resistance	Group 2
Flame supervision device (using SIT series 200 or 290 thermocouples)	
ignition time	< 10 s
shut-off time	< 60 s
number of cycles expected	10.000
Manual shut-off device	
number of cycles expected	10.000

THERMOSTAT REGULATION SPECIFICATIONS

The regulation specifications of the modulating thermostat with on-off function are shown in the following drawing and table:

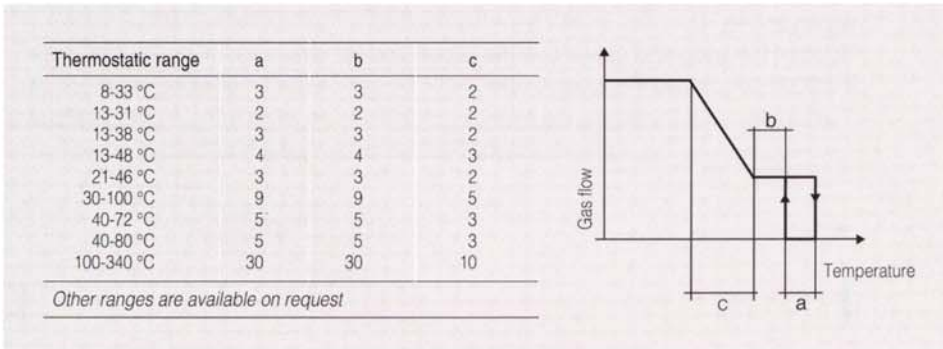

GAS FLOW

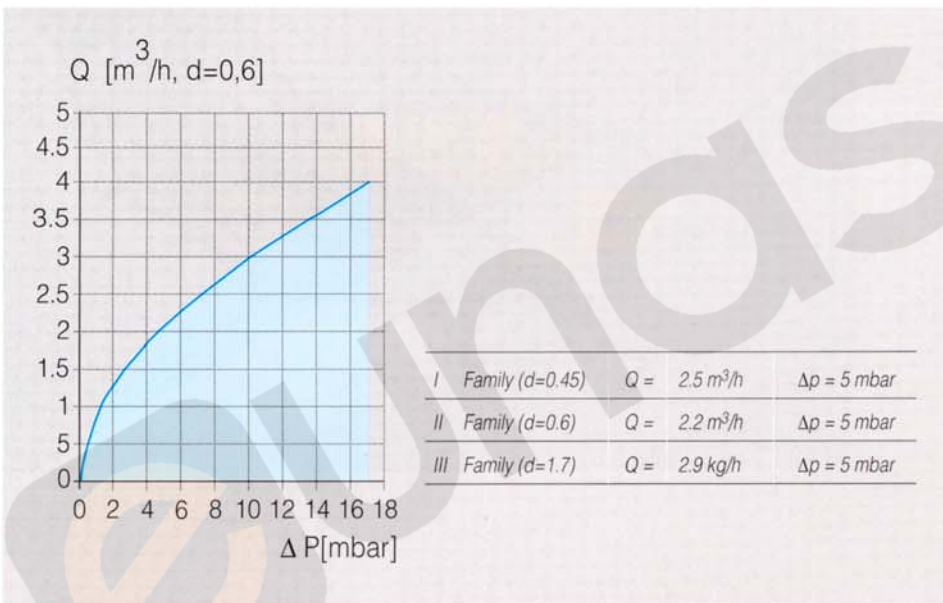

Gas flow Q (15 °C, 1013.25 mbar) as a function of the pressure drop Δp between inlet and outlet with knob in position 7 and cold bulb.

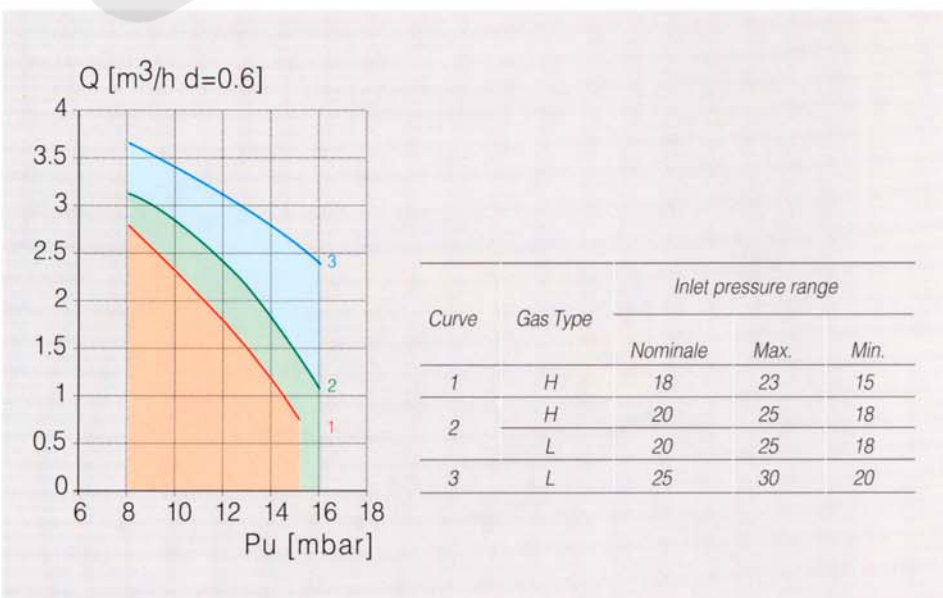

Regulated flow Q (15 °C, 1013.25 mbar) as a function of the outlet pressure P_u with knob in position 7 and cold bulb in accordance with EN 88.

OPERATION

Ignition of pilot flame

Starting from OFF ● position, turn the knob to the pilot position ★ .
Push the knob and ignite the pilot flame keeping the knob depressed for several seconds (Fig. 1).

Release the knob and check that the pilot flame remains alight (Fig. 2).
If it goes out, repeat the ignition operation.

1

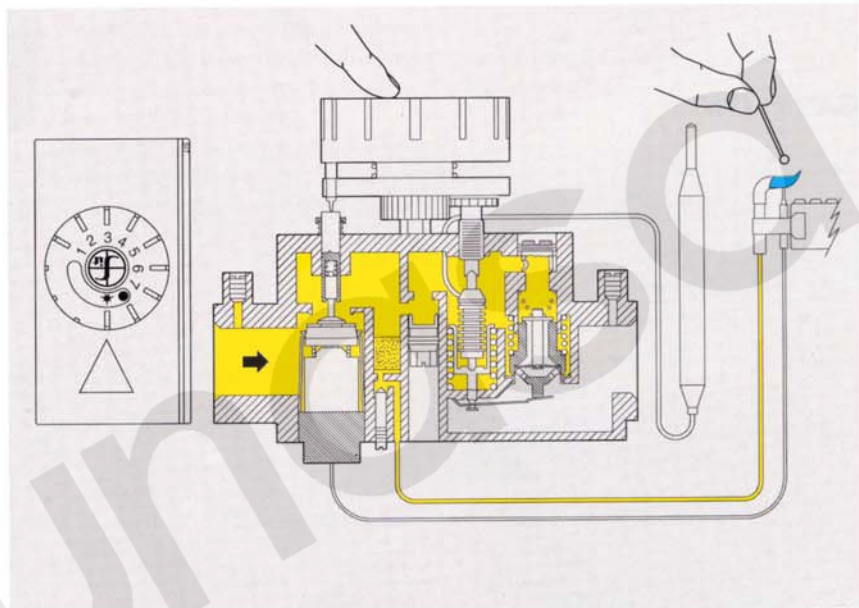

2

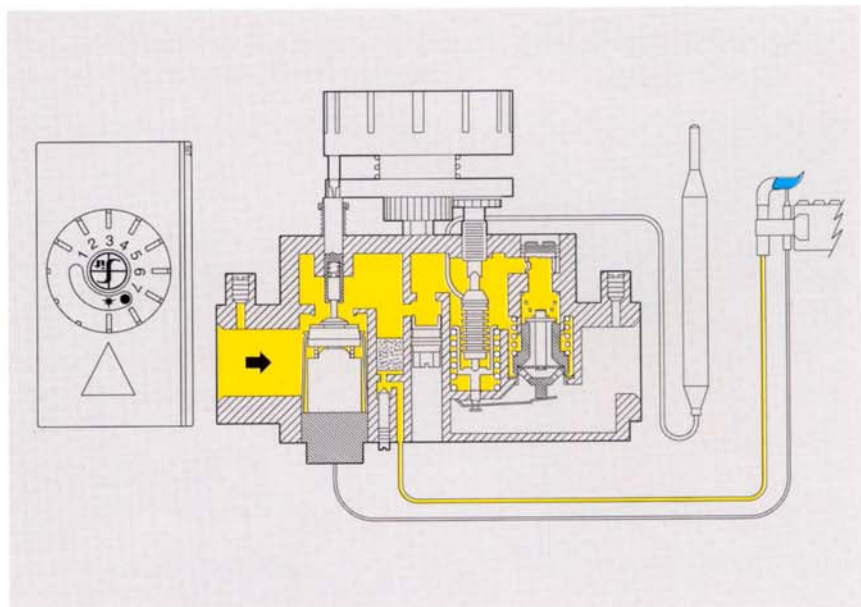

Temperature selection

Turn the knob to the point corresponding to the desired temperature (Fig. 3).

Stand by position

To keep the main burner closed and the pilot flame alight, turn the knob from the selected temperature position to the pilot position **★**.

Extinguishing

Turn the knob to Off **●** position (Fig. 4).

CAUTION: The re-start interlock prevents ignition of the appliance throughout the closing time of the flame supervision device (approx. 60 secs.).

3

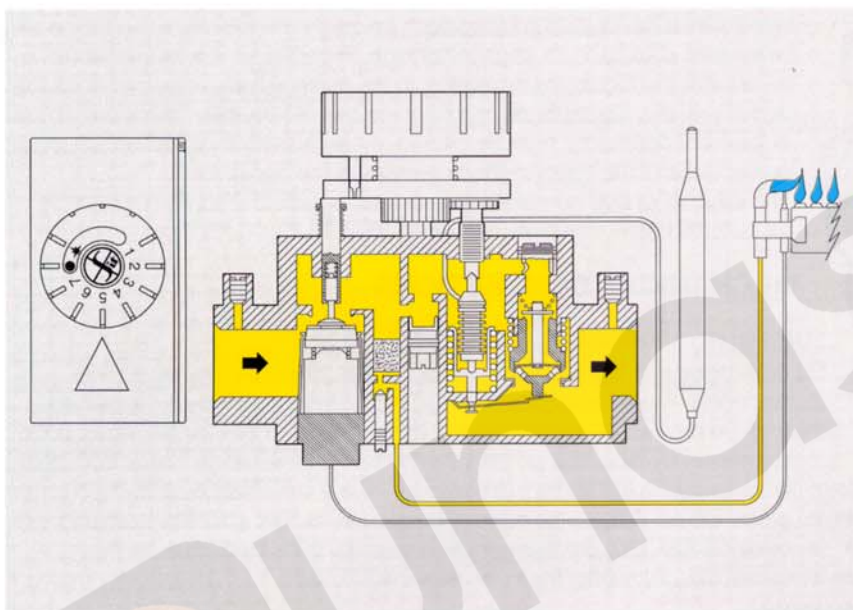

4

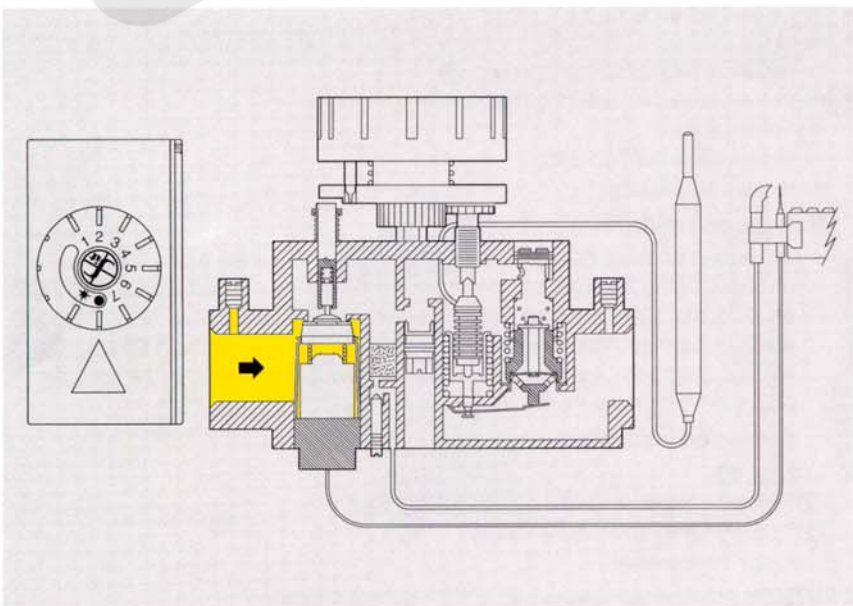

ACCESSORIES

Calibrated maximum flow screws		0.907.630
Calibrated minimum flow screws		0.972.058
Pressure regulator 3-18 mbar		0.958.030
3/8 sealing plug for unused outlets		0.958.031
Nut and Olive connection for connection to pilot burner with pipes of:	ø 4 mm	0.958.032
	ø 6 mm	0.973.044
	ø 1/4	0.073.954
Sand coloured cover with screw		0.997.209
Sand coloured cover with screw and piezo ignition		
Disc adaptor for remote control		
<i>Other accessories are available on request</i>		

INSTALLATION

The 630 EUROSIT complies with current safety standards. Nevertheless, its installation on appliances must be verified in accordance with the specific standards for each installation. In particular, it is necessary to ensure that the requirements relating to the class of flame supervision device and, if present, the pressure regulator are met. All the installation, setting and adjustment operations must be carried out exclusively by qualified personnel on the basis of the specific characteristics of the appliance. The valve must only be installed inside gas appliances and is not suitable for outdoor use.

MECHANICAL CONNECTIONS

General recommendations

Do not tamper with sealed parts. Do not slacken assembly screws. Do not remove labels. Avoid blows (knocks, falls etc.). Only remove dust caps when installing. Do not exceed recommended torques. Ensure that the gas flows in the direction shown by the arrow on the valve body. Prevent foreign matter from getting into the valve during installation. In particular, check the cleanliness of the inlet and outlet pipes. Do not subject the valve to bending in excess of 35 Nm and to torque in excess of 25 Nm. Use only the specified spanner grips when making the connections. The valve has 3 pairs of attachment holes.

CAUTION

To allow personalisation of the product in the installation phase, some versions are supplied without some components. Therefore, check that the valve is supplied complete with:

- minimum gas flow adjustment screw **3** (fig. A)
- maximum gas flow adjustment screw **2** (fig. A) or, alternatively, pressure regulator **2** (fig. A')

If not, assemble as follows:

- check that the component code is correct
- insert the minimum adjustment screw into opening **14**, the maximum screw or the pressure regulator into opening **15**.
- Insert the components and screw in fully.

Tightening torque:

- setting adjustment screws 7 Nm
- pressure regulator: 1 Nm

Main gas connection

The connection must be made using gas pipes with Rp 3/8 ISO 7 thread.

Torque: 25 Nm. Alternatively, it is possible to use the nut and bicone connection for Ø 12 mm pipe (codes 0.958.025 and 0.957.007) (torque 15 Nm). The valve has two main gas inlets (**10** and **12**) and two main gas outlets (**11** and **13**). It is necessary to close the unused inlet and outlet screwing in the specified plug fully (code 0.972.058). Torque 7 Nm.

Connection to the pilot burner

outlet **8**.

Ø 4 mm, Ø 6 mm or Ø 1/4" pipes can be used.

Use appropriately sized nut and olive.

Tighten to 7 Nm torque.

CAUTION: After connecting to gas, check for gas leakage.

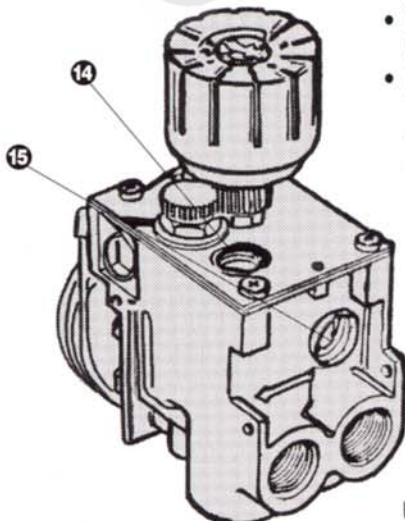
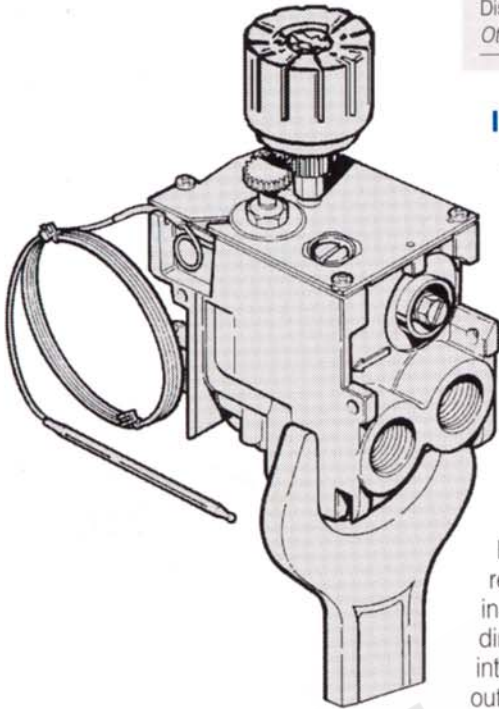

SETTINGS AND ADJUSTMENTS

All adjustments must be made on the basis of the specific characteristics of the appliance. Check inlet and outlet pressure using the pressure test point **6** and **7**. After testing, carefully seal test points with the provided screws. Recommended torque: 2.5 Nm.

Adjusting maximum and minimum outlet flow

These adjustments must be made when the thermostatic bulb is cold.

Maximum flow (versions without pressure regulator) - fig. A.

Turn the knob **4** to position 7. Screw in the adjustment screw **2** fully, turn the adjustment screw anticlockwise to increase the gas flow.

CAUTION: After screwing in fully, do not unscrew the adjustment screw more than two turns.

Overriding the flow adjustment function

Screw in the adjustment screw **2** fully, unscrew it two complete turns and seal it. Alternatively, the gas flow adjustment function may be excluded by substituting the adjustment screw **2** with the plug code 0.972.057. In this case the plug must be fixed firmly.

Maximum flow (versions with pressure regulators) - fig. A'

Turn the knob to position 7. Screw the adjustment screw **2** clockwise to increase gas flow.

Overriding pressure regulator

Rotate the adjustment screw **2** completely in a clockwise direction.

Minimum flow

Starting from position 7, slowly turn the knob clockwise to the minimum flow position (just before the main burner shut-off). Turn screw **3** anticlockwise to increase the flow. It is possible to use screws with calibrated holes (available on request) to replace the maximum and minimum flow adjustment screws. In this case, it is necessary to tighten these screws to a torque of 7 Nm.

Adjustment of gas flow to the pilot burner

Turn screw **5** clockwise to reduce the flow.

Overriding the pilot flow adjustment function

Screw in adjustment screw **5** fully and then unscrew it two complete turns. Seal the adjustment.

Changing the gas family or group

Check that the appliance is suitable for operation with the gas family or group desired. Following the instructions given above, adjust the outlet pressure to the values given in the appliance's instruction booklet. With Family III gas: override the maximum flow adjustment or the pressure regulator according to the version. Override the adjustment of the gas flow to the pilot burner.

IMPORTANT: At the end of all setting and adjustment operations, check gas seals and the efficiency of the appliance. It is particularly important to check that flame lift or light back to minimum and maximum outlet pressures are absolutely impossible. After carrying out all adjustments, fit the provided seals and/or block the setting screws with paint.

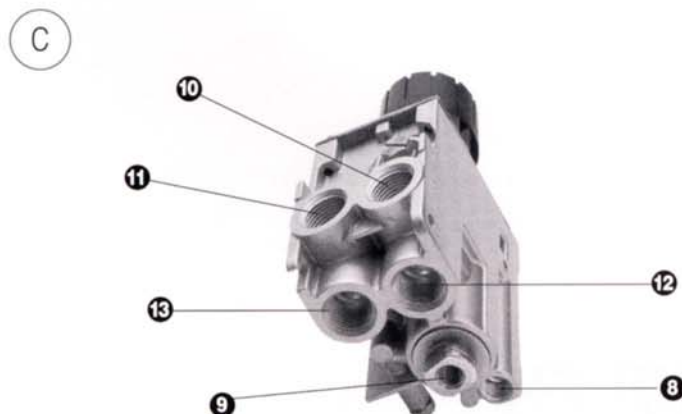
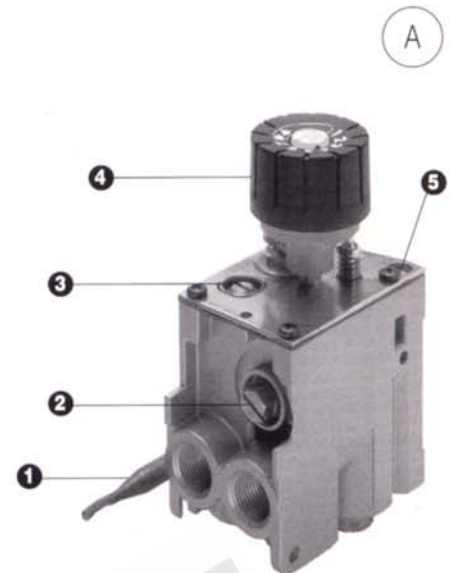

MAINTENANCE

The only maintenance operation permitted is the replacement of the magnet unit. This operation must be carried out by qualified personnel only and according to the instructions provided in the instruction leaflet supplied with the spare parts.

DIMENSIONS

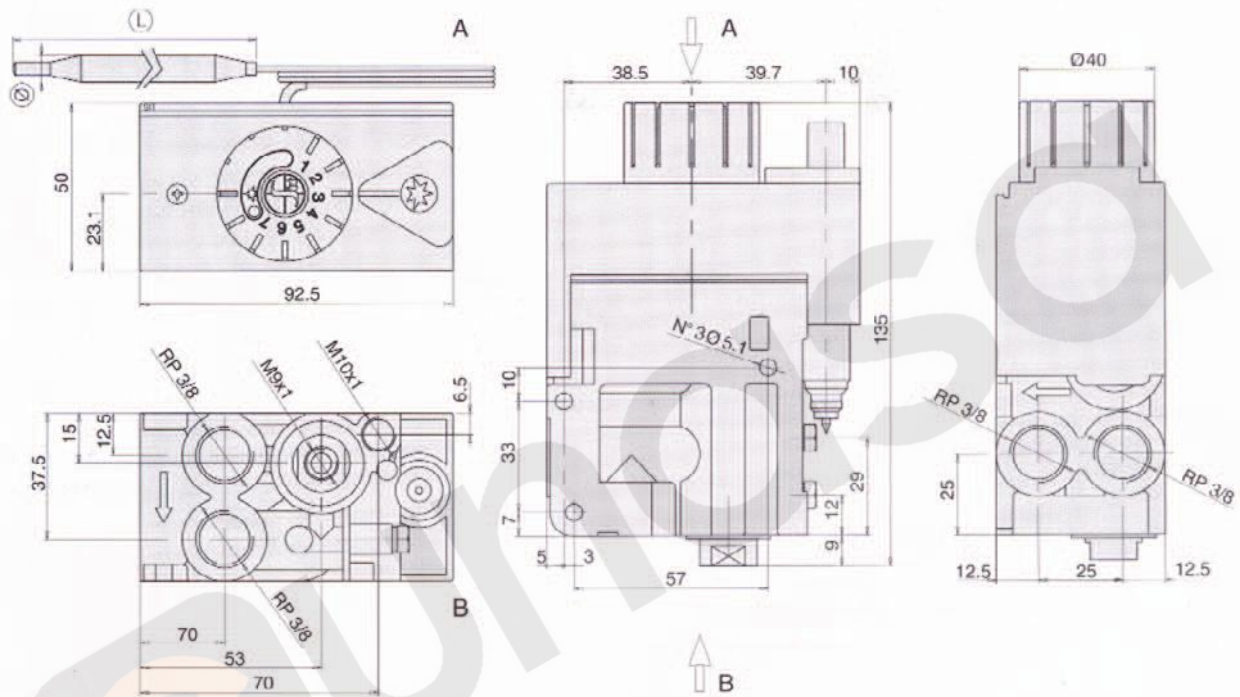

⊙	8	8	8	8	8	5	8	8	5	4
L	120	155	120	95	120	122	90	90	68	72
T	8-33 °C	13-31 °C	13-38 °C	13-48 °C	21-46 °C	30-100 °C	40-72 °C	40-60 °C	100-340 °C	100-340 °C