

Series NS2™

OEM AIR PRESSURE SENSING SWITCHES WITH FIXED SET POINT

APPLICATION

Series NS2™ Air Flow Pressure Sensing Switches are designed with sturdy, contaminant-free construction, to provide low cost, high accuracy and reliability. NS2 switches offer a narrow switching differential and low set point tolerance over a wide operating temperature and set point range. They can be used to sense positive, negative or differential air pressure. Factory-calibrated set points are available from 0.05" to 10.0"w.c.

The glass-filled polycarbonate body of the switch provides a high degree of stability and accommodates many sample line connector options. The high and low pressure ports are color-coded for ease of identification. Port, bracket, and terminal orientations can be specified. The integral snap-acting switch mechanism (patent pending) is available in SPNO, SPNC, and SPDT terminal configurations.

An optional bleed hole is available, as well as numerous standard and custom mounting brackets. Please consult Cleveland Controls about the many custom features we offer.

GENERAL DESCRIPTION & OPERATION

The glass-filled polycarbonate housing contains a sensing diaphragm and includes an integral snap-acting switch. Sample line connectors are located on either or both sides of the diaphragm to accept air sample connections.

The electrical connection consists of male 90° quick-connect terminals. The snap action switch can be actuated by a pressure or vacuum air flow, or by a pressure or vacuum differential.

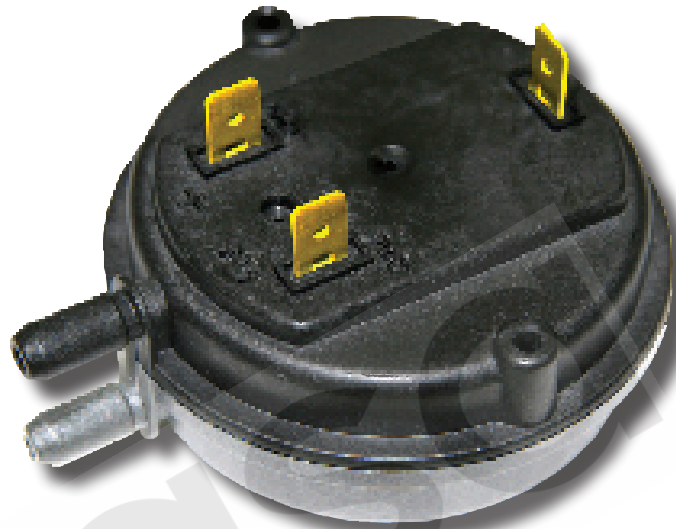

MOUNTING

Various mounting brackets are available. Figure 1 shows two typical styles. Select a mounting location free from vibration. Mount with the diaphragm vertical, or at a custom angle. Specify the mounting position when ordering. Avoid mounting with the sample line connections directed upward.

ELECTRICAL CONNECTIONS

The snap switch has 90° male quick connect terminals in 1/4" (standard) or 3/16" (optional) sizes. Before pressure is applied to the diaphragm, the switch contacts will be in the deactivated position as shown in Figure 2.

AIR SAMPLING CONNECTION

Series NS2 switches are available with many different types of sample line connections that accept a wide range of flexible and rigid sample line tubing. See Figure 3.

AIR SAMPLING METHOD

The High or Positive inlet (P1) is black and the Low or Negative inlet (P2) is gray. Connect the sample lines as follows:

Positive Pressure Only: Connect the sample line to P1; P2 remains open to the atmosphere.

Negative Pressure Only: Connect the sample line to P2; P1 remains open to the atmosphere.

Two Negative Samples: Connect higher negative sample to P2; lower sample to P1.

Two Positive Samples: Connect higher positive sample to P1; lower sample to P2.

One Positive and One Negative: Connect positive sample to P1; connect negative sample to P2.

Figure 1A: Half Strap Bracket

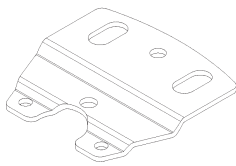

Figure 1B: "L" Bracket

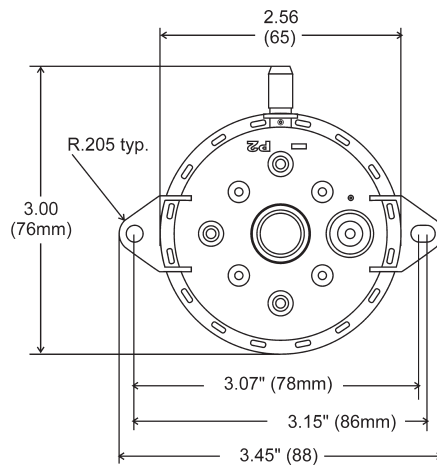
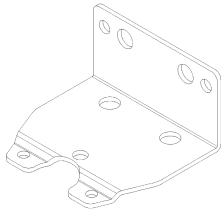

Figure 1C: Standard Integral Bracket

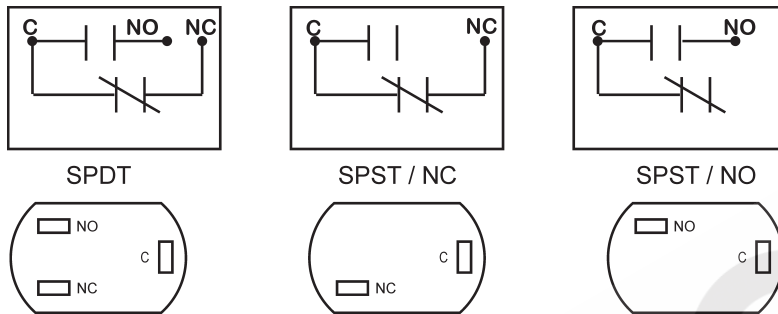

Fig. 2 Without pressure applied to the diaphragm, switch contacts are in the position shown.

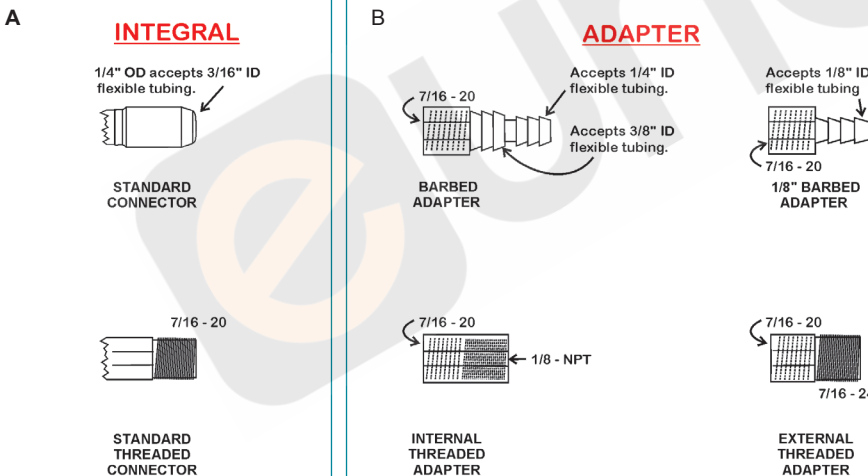
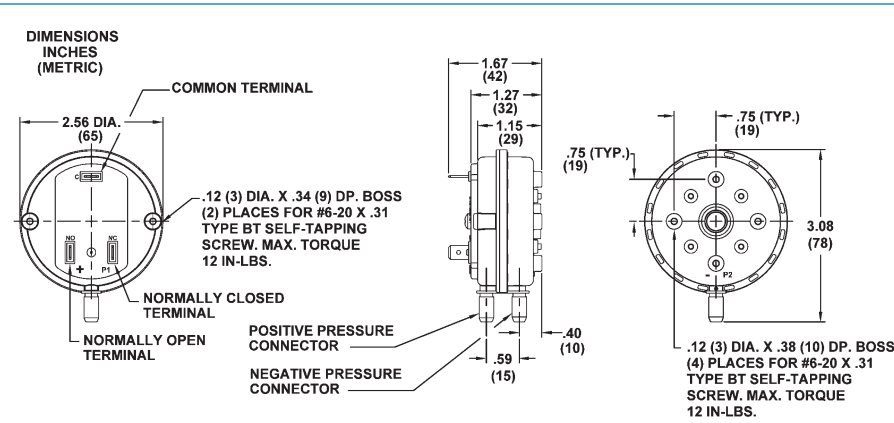

Figure 3: Sample Line Connector Options: (A) Integral connectors; (B) Adapters



TECHNICAL SPECIFICATIONS

Material	
Body	Glass-filled polycarbonate.
Diaphragm	Post-cured silicone.
Terminals	Copper alloy.
Contacts	Standard: fine silver. Optional: gold alloy.
Operation	
Operating Range	0.05"w.c to 10.0"w.c.
Max. Pressure Rating	14"w.c.
Mounting	Standard diaphragm: vertical or custom angle. Consult factory.
Operating Temperature	-40 to +88C. (-40 to +190F).
Sample Line Connections	Black positive. Gray negative. Many configurations are available.
Sample Medium	Air and byproducts of combustion that will not degrade silicone or polycarbonate.
Product Life	100,000 cycles minimum.
Electrical	
Electrical Rating	Standard Silver Contacts: SPDT, SPST Electrical load: 1/10 HP @120 to 277 Vac; 28 VA pilot duty @ 24 Vac; 125 VA pilot duty @ 120 Vac. SPST Electrical load: 5 Amps resistive @ 24, 120 to 277 Vac. Optional Gold Contacts: .15 Amp resistive @ 24Vac or Vdc.
Contact Arrangement	SPNO, SPNC, SPDT.
Electrical Connectors	Standard quick-connect terminals: 1/4" x 0.032 . Optional quick-connect terminals: 3/16" x 0.032.
General	
Approvals	UL, CUL, CSA, CE, Australian Gas Assoc.
Accessories	Consult Factory.